



## GRANDTREK AT3G

Dunlop's new 3-ply SUV/4x4 tyre – a rugged pattern for rugged terrain. Reinforced 3-ply sidewall (A) and a thick shoulder buttress inspired by rally designs (B) help prevent sidewall damage and penetration while also providing higher load-bearing capabilities.

The aggressive pattern design with wide grooves ensures better grip on all terrains with stone ejectors to enhance self-cleaning properties and prevent stone-trapping (D). The staggered pattern design extends to the shoulder block (C) to further assist in all terrain grip and penetration prevention, particularly when tyre pressures are lowered in line with terrain requirements.

### 3-PLY CONSTRUCTION

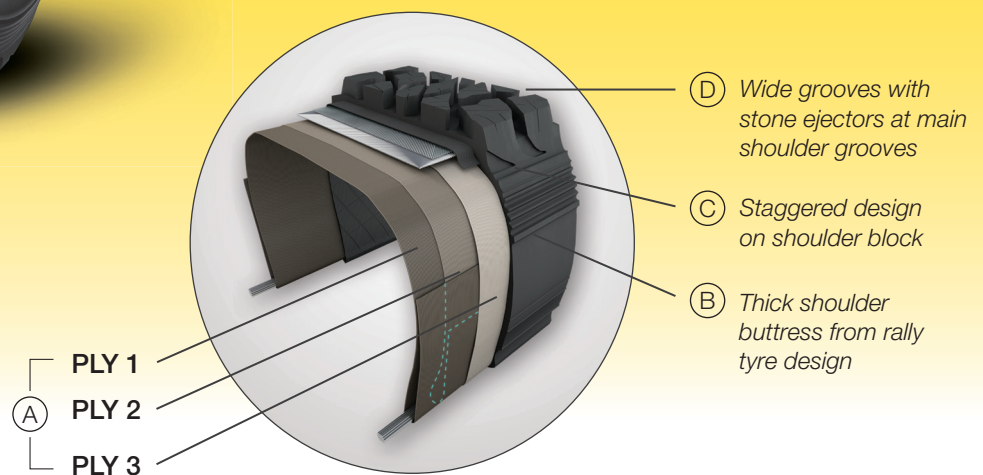

SRSA code	Tyre Size	Ply Rating	Load Index	Speed Index	MFS	Overall Diameter (mm)	Section Width (mm)	Recommended Rim (J)	Sidewall	OE
G11291270DJ	LT235/85R16	-	120/116	S	-	806	233	6,5	BLK	
G11291268DJ	LT30X9.50R15	-	104	S	-	750	238	7,5	BLK	
G11291269DJ	LT31X10.50R15	-	109	S	-	775	266	8,5	BLK	
G11291272DJ	LT245/75R16	-	121/118	Q	-	774	246	7,0	BLK	
G11291274DJ	LT265/75R16	-	123/120	Q	-	804	265	7,0	BLK	
G11291271DJ	245/70R16	-	111	S	-	750	246	7,0	BLK	
G11291273DJ	LT265/70R16	-	121/118	R	-	778	270	8,0	BLK	
G11291276DJ	LT265/70R17	-	121/118	R	-	804	270	8,0	BLK	
G11291278DJ	LT285/70R17	-	121/118	S	-	838	290	8,0	BLK	
G11291275DJ	LT265/65R17	-	120/117	R	-	776	270	8,0	BLK	
G11291277DJ	LT275/65R17	-	121/118	R	-	790	277	8,0	BLK	
G11291279DJ	285/65R17	-	116	S	-	802	290	8,5	BLK	
G11291280DJ	265/60R18	-	114	S	-	775	270	8,0	BLK	

# BEYOND THE DESERT EDGE

Around mid-2017 world renowned professional adventurer Peter van Kets approached us with a new adventure series he was planning with the highly talented and publicised photo-journalist Jacques Marais and crew. They were planning a trip to mountainbike from the Angolan border through the most unforgiving and wild, yet beautiful, terrains along the Namibian desert edge to Walvis Bay. A reliable tyre partner was critical and with our new AT3G 3-ply offering freshly landed, Dunlop helped drop them Beyond the Desert Edge, shodding the support vehicles with tyres that could travel comfortably on-road and withstand a severe pounding across a variety of terrains. From “razor-sharp shale” as Peter explained it, to rocks, sand, gravel and tar, the AT3G never missed a beat and comfortably traversed the crew over 7 000KM of overland expedition.

We took the tyres off for inspection after the expedition and we were seriously impressed at their condition. Barely worn and with minor scuffing from the terrain, the tyres had surpassed expectations. A pattern that has emerged in testing conducted since the expedition. The pictures tell part of the story but Peter and Jacques are probably the best to catch over a campfire sometime and explain exactly what they put the tyres and vehicles through as Jacques candidly once admitted to driving along this treacherous terrain in a manner “.I would never drive in a vehicle of my own.”

Stop making excuses! Take the road! Take on any road! Take it on!

